



DMHD – Technical Features



Standard Features

- Self-supporting column in extruded anodized aluminium with high load torque capability
- Onboard electronics with many optional functions
- 12 or 24 Vdc as standard input voltages
- Static load up to 18 kN (4050 lbf)
- Dynamic load up to 16 kN (3584 lbf)
- Stroke up to 600 mm
- Speed up to 71 mm/s (2.8 in/s)
- Protection class static IP65
- Rugged, robust and strong
- T-slot grooves along the entire profile
- Maintenance free

General Specifications

Screw type	ball
Nut type	load lock ball nut
Manual override	no
Anti-rotation	yes
Static load holding brake	yes
Safety features	Electrak monitoring package: current monitoring voltage monitoring temperature monitoring load trip point calibration internal end-of-stroke limit switches ⁽¹⁾ end-of-stroke dynamic braking
Electrical connections	cable with flying leads
Compliances	CE

(1) Dynamic braking is included at the ends of stroke for all DMHD actuators. Dynamic braking offered throughout the entire stroke length only on low-level switching and J1939 options.

Optional Electronic Control Features

CANopen CAN bus
SAE J1939 CAN bus
Synchronization option
Low-level switching
End-of-stroke indication output
Analog position output
Digital position output

Control Option Combinations

Same as for Electrak HD - see table on page 20

Accessories

T-slot bolts

Compatible Controls

Contact customer support at www.thomsonlinear.com/cs

DMHD – Technical Specifications

Mechanical Specifications		
Max. static load ⁽¹⁾	[kN (lbf)]	18 (4050)
Max. dynamic load (Fx)	[kN (lbf)]	
DMHDxxB017		1.7 (382)
DMHDxxB026		2.6 (585)
DMHDxxB045		4.5 (1012)
DMHDxxB068		6.8 (1529)
DMHDxxB100		10 (2248)
DMHDxxB160		16 (3584)
Max. load torque, dyn. and static	[Nm (lbf-in)]	710 (6284)
Speed @ no load/max. load ⁽²⁾	[mm/s (in/s)]	
DMHDxxB017		71/58 (2.8/2.28)
DMHDxxB026		40/32 (1.6/1.3)
DMHDxxB045		24/19 (0.94/0.75)
DMHDxxB068		18/14 (0.71/0.55)
DMHDxxB100		11/9 (0.43/0.35)
DMHDxxB160		7/5 (0.27/0.21)
Min. ordering stroke (S) length	[mm]	100
Max. ordering stroke (S) length ⁽³⁾	[mm]	600
Ordering stroke length increments	[mm]	50
Operating temperature limits	[°C (F)]	-40 – 85 (-40 – 185)
Full load duty cycle @ 25 °C (77 °F)	[%]	25 ⁽⁴⁾
End play, maximum	[mm (in)]	1.2 (0.047)
Protection class - static		IP65

¹ Max. static load at fully retracted stroke.

² For units with the synchronization option, the speed is 25% lower at any load.

³ 500 mm max. for 16 kN

⁴ For DMHDxx-B100 and DMHDxx-160, unidirectional load, the duty cycle is 15%.

Electrical Specifications		
Available input voltages	[Vdc]	12, 24
Input voltage tolerance	[Vdc]	
DMHD12 (12 Vdc input voltage)		9 - 16
DMHD24 (24 Vdc input voltage)		18 - 32
Current draw @ no load/max. load	[A]	
DMHD12B017		3/18
DMHD24B017		1.5/9
DMHD12B026		3/18
DMHD24B026		1.5/9
DMHD12B045		3/18
DMHD24B045		1.5/9
DMHD12B068		3/20
DMHD24B068		1.5/10
DMHD12B100		3/18
DMHD24B100		1.5/9
DMHD12B160		3/20
DMHD24B160		1.5/10
Motor leads cross section	[mm ² (AWG)]	2 (14)
Signal leads cross section	[mm ² (AWG)]	0.5 (20)
Standard cable lengths	[m (in)]	1.5, 5 (59, 197)
Cable diameter	[mm (in)]	7.5 (.295)
Flying lead length	[mm (in)]	76 (3)
Stripped lead length	[mm (in)]	6 (0.25)



DMHD – Dimensions

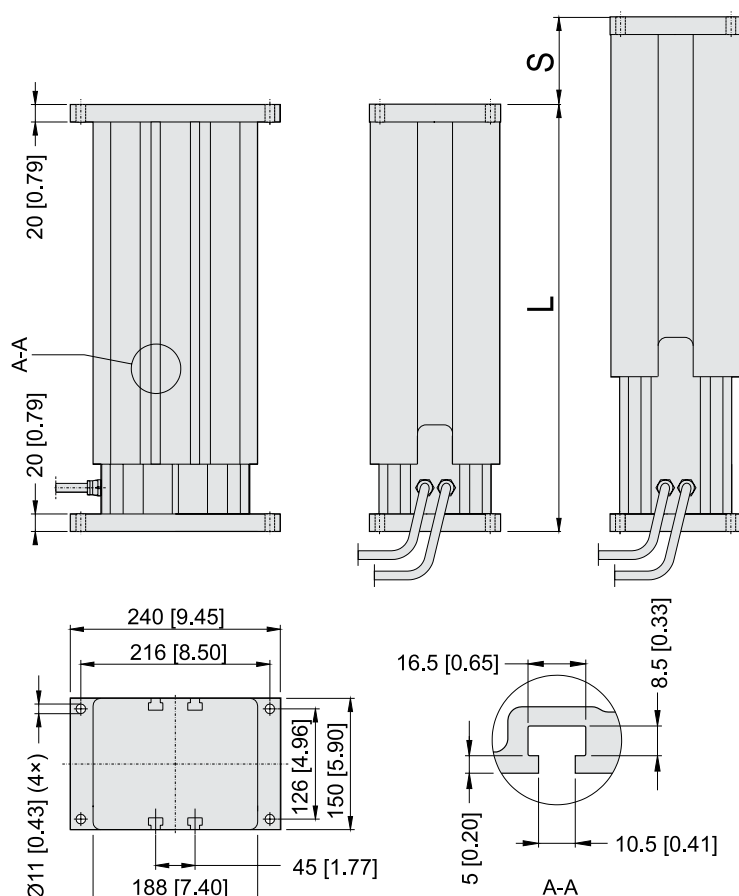

Dimensions	Projection
mm [inch]	

Note. All models have two cables except models with control option EXX which has one placed in the center of the profile.

Stroke, Retracted Length and Weight Relationships												
Ordering stroke (S)	[mm]	100	150	200	250	300	350	400	450	500	550	600
Retracted length (A) for DMHDxxB017(026,045,068)	[mm]	357	407	457	507	557	657	707	757	807	857	907
	[in]	14.1	16.0	18.0	20.0	21.9	23.9	27.8	29.8	31.8	33.7	35.7
Weight for DMHDxxB017(026,045,068)	[kg]	21.8	23.3	24.9	26.4	28.0	30.8	32.3	33.8	35.5	37.0	38.5
	[lbf]	48.0	51.3	54.8	58.1	61.6	67.8	71.1	74.4	78.1	81.4	84.7
Retracted length (A) for DMHDxxB100	[mm]	407	457	507	557	607	657	707	757	807	857	907
	[in]	16.0	18.0	20.0	21.9	23.9	23.9	27.8	29.8	31.8	33.7	35.7
Weight for DMHDxxB100	[kg]	22.0	23.6	25.1	26.7	28.2	31.1	32.5	34.7	36.4	38.0	39.5
	[lbf]	48.4	51.9	55.2	58.7	62.0	68.4	71.5	76.3	80.1	83.6	86.9
Retracted length (A) for DMHDxxB160 *	[mm]	407	457	507	557	607	657	707	757	807	-	-
	[in]	16.0	18.0	20.0	21.9	23.9	23.9	27.8	29.8	31.8	-	-
Weight for DMHDxxB160 *	[kg]	22.3	23.9	25.4	27.0	28.5	31.4	32.5	34.7	36.4	-	-
	[lbf]	49.1	52.6	55.9	59.4	62.7	69.1	71.5	76.3	80.1	-	-

* Max. stroke for DMHDxxB160 (16 kN (3584 lbf)) is 500 mm.

DMHD – Performance Diagrams

Load vs. Speed ⁽¹⁾

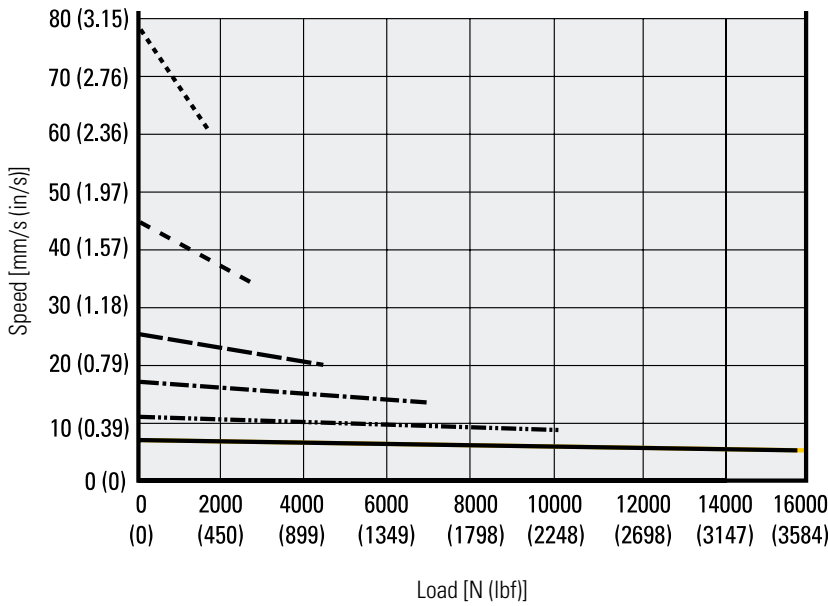

Off Center Load Capacity

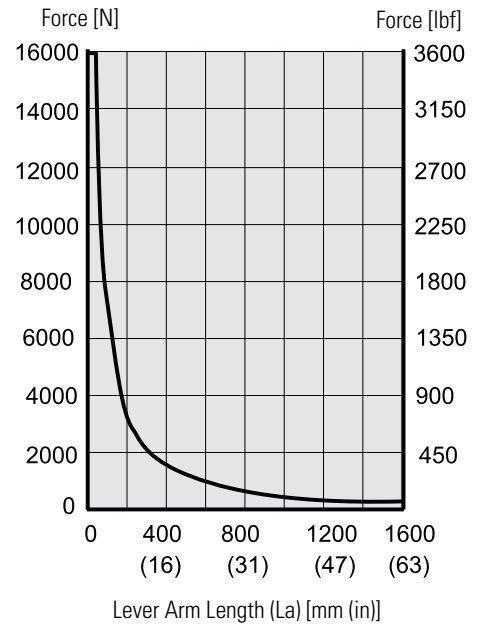

¹ Curves valid for all units except those with the synchronization option, where the speed at any load is 25% lower than for those without.

Load vs. Current

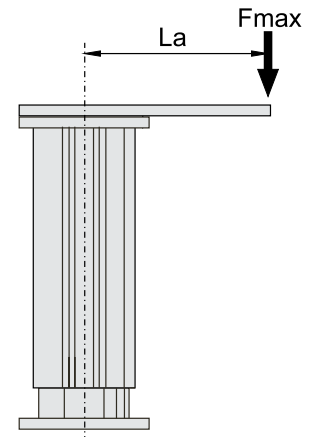
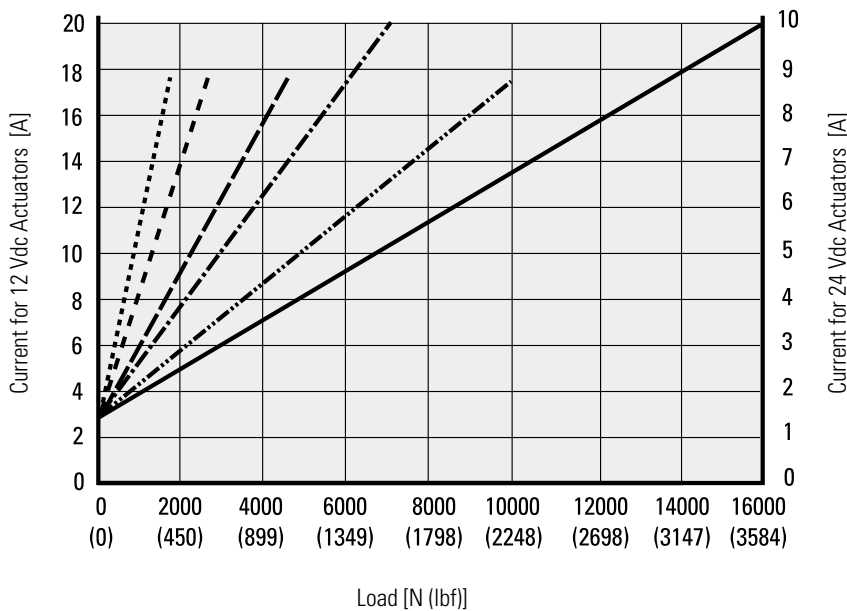

- | | | | | | |
|-------------------------------|---------|--------------------------------|-----------|-------------------------------|-------|
| DMHDxxB017 (1.7 kN (382 lbf)) | | DMHDxxB045 (4.5 kN (1012 lbf)) | ---- | DMHDxxB100 (10 kN (2248 lbf)) | ----- |
| DMHDxxB026 (2.6 kN (585 lbf)) | - - - - | DMHDxxB068 (6.8 kN (1529 lbf)) | - . - . - | DMHDxxB160 (16 kN (3584 lbf)) | ———— |

Note! Curves were generated at an ambient temperature of 21°C (70°F). Different ambient temperature and individual actuator characteristics can produce slightly different values.

DMHD – Ordering Key

Ordering Key				
1	2	3	4	5
DMHD12-	B026-	0300	LXX	5
<p>1. Model and input voltage DMHD12- = lifting column type DMHD, 12 Vdc DMHD24- = lifting column type DMHD, 24 Vdc</p> <p>2. Screw type, dynamic load capacity B017- = ball screw, 1.7 kN (382 lbf) B026- = ball screw, 2.6 kN (585 lbf) B045- = ball screw, 4.5 kN (1012 lbf) B068- = ball screw, 6.8 kN (1529 lbf) B100- = ball screw, 10 kN (2248 lbf) B160- = ball screw, 16 kN (3584 lbf)</p> <p>3. Ordering stroke length ^{(1) (2)} 0100 = 100 mm 0150 = 150 mm 0200 = 200 mm 0250 = 250 mm 0300 = 300 mm 0350 = 350 mm 0400 = 400 mm 0450 = 450 mm 0500 = 500 mm 0550 = 550 mm 0600 = 600 mm</p>	<p>4. Electrak Modular Control System options EXX = Electronic Monitoring Package only ELX = EXX + end-of-stroke indication output EXP = EXX + analog (potentiometer) position output EXD = EXX + digital position output ELP = ELX + analog (potentiometer) position output ELD = ELX + digital position output LXX = EXX + low-level signal motor switching LLX = EXX + LXX + end-of-stroke indication output LXP = EXX + LXX + analog (potentiometer) position output CNO = SAE J1939 CAN bus + open-loop speed control COO = CANopen CAN bus + open-loop speed control SYN = LXX + Synchronization option</p> <p>5. Cable length and connection type 1 = 1.5 m long cable with flying leads 2 = 5.0 m long cable with flying leads</p> <p>(1) Other stroke lengths available upon request. Contact customer support (2) Max. stroke for DMHDxxB160 (16 kN (3584 lbf)) is 500 mm.</p>			

DMHD – Electrical Connections

Option Type EXX

Actuator supply voltage	[Vdc]	
DMHD12		12
DMHD24		24

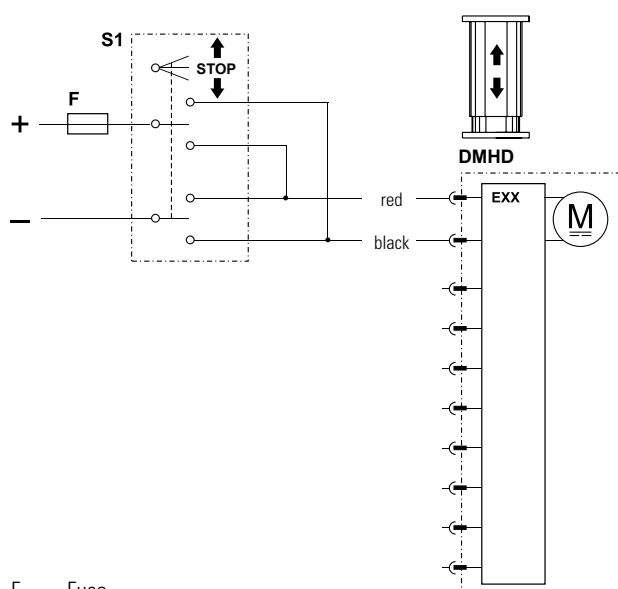

F Fuse

S1 Double pole double throw switch

Control option EXX contains Electrak Monitoring Package features, guaranteeing safe operation of the actuator and equipment. With control option EXX, the polarity of the motor voltage is switched by a customer-supplied switch (switch, relay, etc.) to make the actuator extend or retract. The switch, power supply, wiring and all other components must be able to handle the motor current for the actuator model and load being used, as well as the inrush current (up to three times the max. continuous current for the max. load being used for up to 150 milliseconds).

Option Type ELX

Actuator supply voltage	[Vdc]	
DMHD12		12
DMHD24		24
Output contact type		potential free
Limit switch max. switch voltage	[Vdc]	140
Limit switch max. switch current	[mA]	350
Limit switch max. switch power	[W]	5

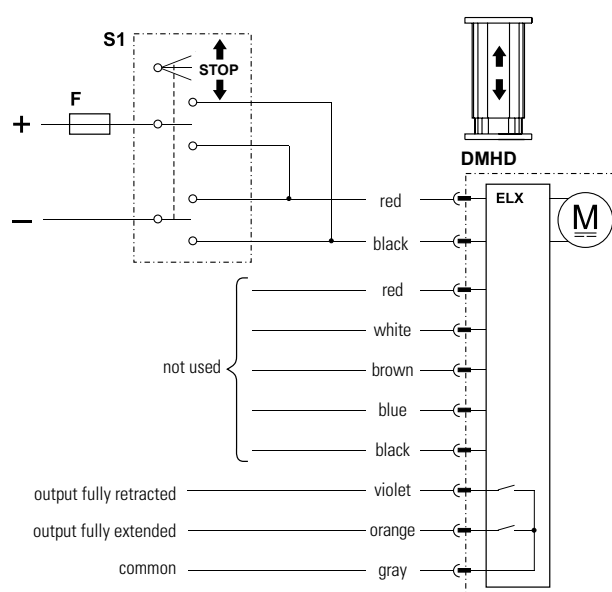

F Fuse

S1 Double pole double throw switch

Control option ELX works as option EXX but also has two outputs that indicate when the extension tube is in its fully extended or retracted position.



DMHD – Electrical Connections

Option Type EXP		
Actuator supply voltage	[Vdc]	
DMHD12		9 - 16
DMHD24		18 - 32
Potentiometer type		wire-wound
Potentiometer max. input voltage	[Vdc]	32
Potentiometer max. power	[W]	1
Potentiometer linearity	[%]	± 0.25
Potentiometer output resolution	[ohm/mm]	
50 - 100 mm stroke		65.6
150 - 250 mm stroke		32.8
300 - 500 mm stroke		19.7
550 - 600 mm stroke		9.8

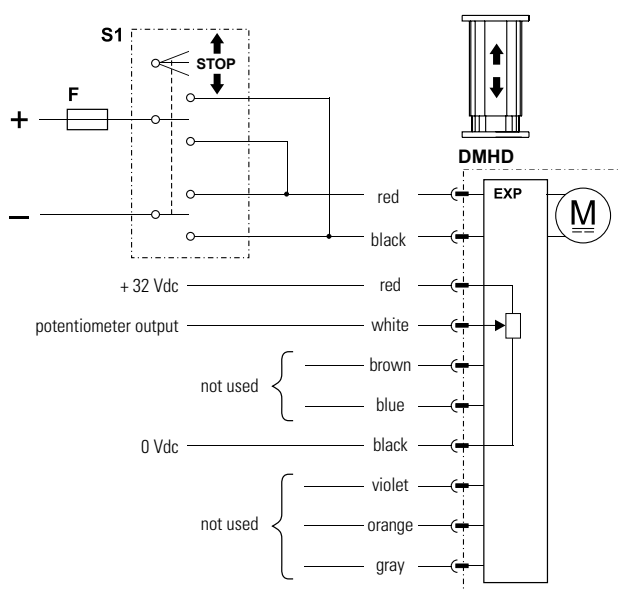

F Fuse
S1 Double pole double throw switch

Control option EXP works as option EXX but also has an analog (potentiometer) output that will provide feedback on the extension tube position.

Option Type EXD		
Actuator supply voltage	[Vdc]	
DMHD12		9 - 16
DMHD24		18 - 32
Encoder type		hall effect
Encoder input voltage	[Vdc]	4 - 24
Encoder output voltage levels	[Vdc]	
low (logical zero), typical / max.		0.1 / 0.25
Encoder resolution	[mm/pulse]	
DMHDxx-B017		0.28
DMHDxx-B026		0.15
DMHDxx-B045		0.09
DMHDxx-B068		0.07
DMHDxx-B100		0.04
DMHDxx-B160		0.03

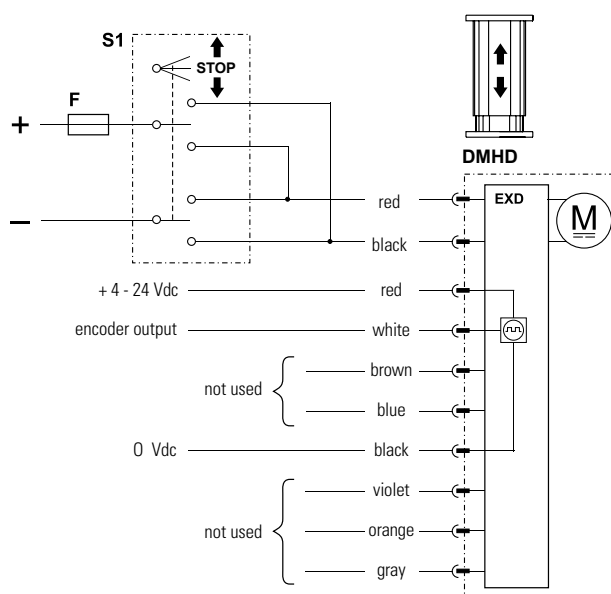

F Fuse
S1 Double pole double throw switch

Control option EXD works as option EXX but also has a single-channel encoder output that will provide feedback on the extension tube position.

DMHD – Electrical Connections

Option Type ELP		
Actuator supply voltage	[Vdc]	
DM HD12		9 - 16
DMHD24		18 - 32
Output contact type		potential free
Max. output voltage	[Vdc]	140
Max. output current	[mA]	350
Max. output power	[W]	5
Potentiometer type		wire-wound
Potentiometer max. input voltage	[Vdc]	32
Potentiometer max. power	[W]	1
Potentiometer linearity	[%]	± 0.25
Potentiometer output resolution	[ohm/mm]	
50 - 100 mm stroke		65.6
150 - 250 mm stroke		32.8
300 - 500 mm stroke		19.7
550 - 600 mm stroke		9.8

Option Type ELD		
Actuator supply voltage	[Vdc]	
DMHD12		9 - 16
DMHD24		18 - 32
Output contact type		potential free
Max. output voltage	[Vdc]	140
Max. output current	[mA]	350
Max. output power	[W]	5
Encoder type		hall effect
Encoder input voltage	[Vdc]	4 - 24
Encoder output voltage levels	[Vdc]	
low (logical zero), typical / max.		0.1 / 0.25
Encoder resolution	[mm/pulse]	
DMHDxx-B017		0.28
DMHDxx-B026		0.15
DMHDxx-B045		0.09
DMHDxx-B068		0.07
DMHDxx-B100		0.04
DMHDxx-B160		0.03

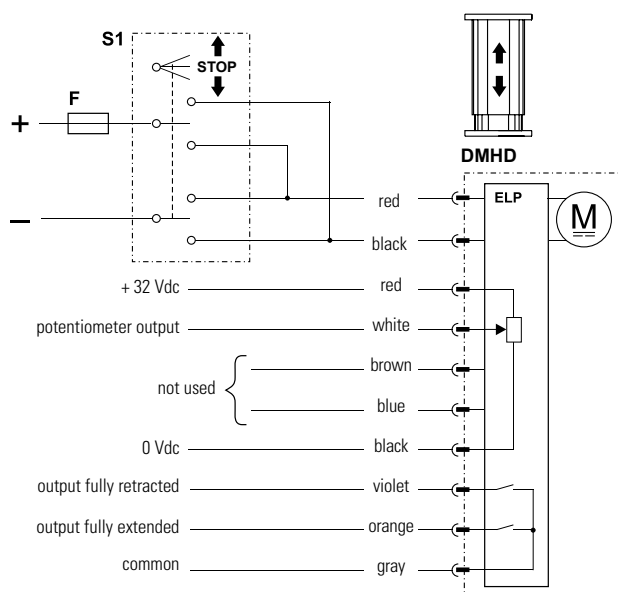

F Fuse
S1 Double pole double throw switch

Control option ELP works as option EXP but also has two outputs that indicate when the extension tube is in its fully extended or retracted position.

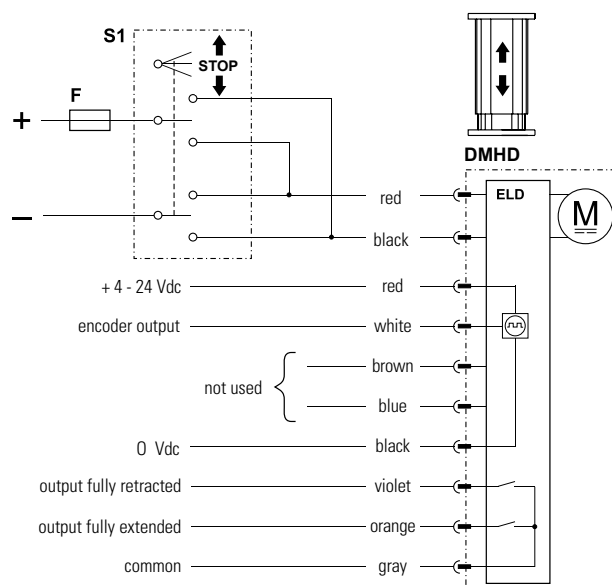

F Fuse
S1 Double pole double throw switch

Control option ELD works as option EXD but also has two outputs that indicate when the extension tube is in its fully extended or retracted position.



DMHD – Electrical Connections

Option Type LXX		
Actuator supply voltage	[Vdc]	
DMHD12		9 - 16
DMHD24		18 - 32
Extend / retract input voltage	[Vdc]	9 - 32
Extend / retract input current	[mA]	6 - 22

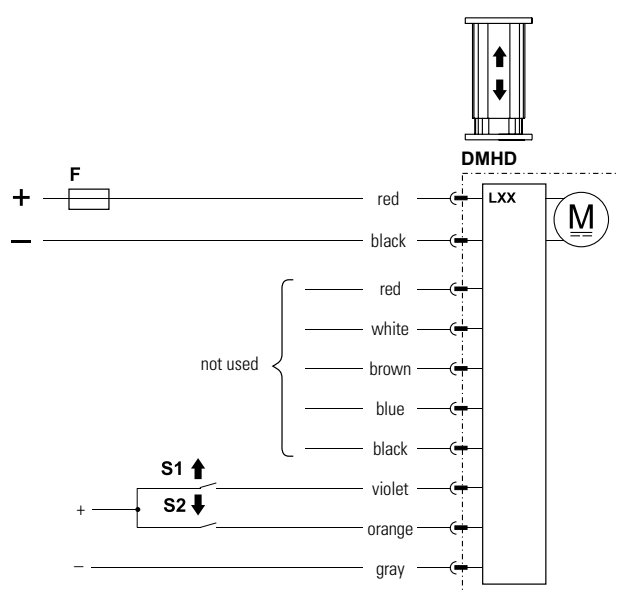

- F Fuse
- S1 Extend switch
- S2 Retract switch

Control option LXX has all the basic Electrak Monitoring Package features included in control option EXX, but the polarity of the motor voltage is switched by the onboard electronics instead. The customer-supplied switches used to command the actuator to extend or retract only need to handle low-level signals. However, the power supply and wiring that supply the actuator must be able to handle the motor current for the actuator model and load being used, as well as the inrush current (up to one and a half times the max. continuous current for the max. load being used for up to 150 milliseconds).

Option Type LLX		
Actuator supply voltage	[Vdc]	
DMHD12		9 - 16
DMHD24		18 - 32
Output contact type		potential free
Max. switched output voltage	[Vdc]	140
Max. output current	[mA]	350
Max. output power	[W]	5
Extend / retract input voltage	[Vdc]	9 - 32
Extend / retract input current	[mA]	6 - 22

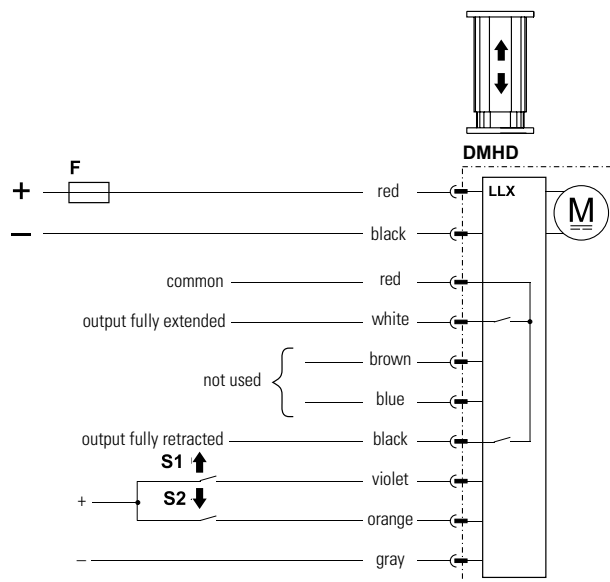

- F Fuse
- S1 Extend switch
- S2 Retract switch

Control option LLX works as option LXX but also has two outputs that indicate when the extension tube is in its fully extended or retracted position.

DMHD – Electrical Connections

Option Type LXP		
Actuator supply voltage	[Vdc]	
DMHD12		9 - 16
DMHD24		18 - 32
Potentiometer type		wire-wound
Potentiometer max. input voltage	[Vdc]	32
Potentiometer max. power	[W]	1
Potentiometer linearity	[%]	± 0.25
Potentiometer output resolution	[ohm/mm]	
50 - 100 mm stroke		65.6
150 - 250 mm stroke		32.8
300 - 500 mm stroke		19.7
550 - 600 mm stroke		9.8
Extend / retract input voltage	[Vdc]	9 - 32
Extend / retract input current	[mA]	6 - 22

Option Type CNO and COO

Option Type CNO and COO		
Actuator supply voltage	[Vdc]	
DM HD12		9 - 16
DMHD24		18 - 32
Command data includes:		
• position		
• speed		
• current		
Feedback data includes:		
• position		
• speed		
• current		
• other diagnostic information		

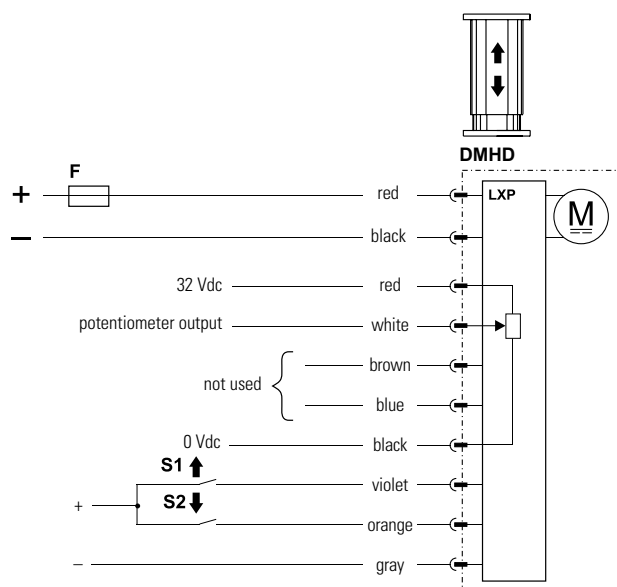

- F Fuse
- S1 Extend switch
- S2 Retract switch

Control option LXP works as option LXX but also has an analog (potentiometer) output that will provide feedback on the extension tube position.

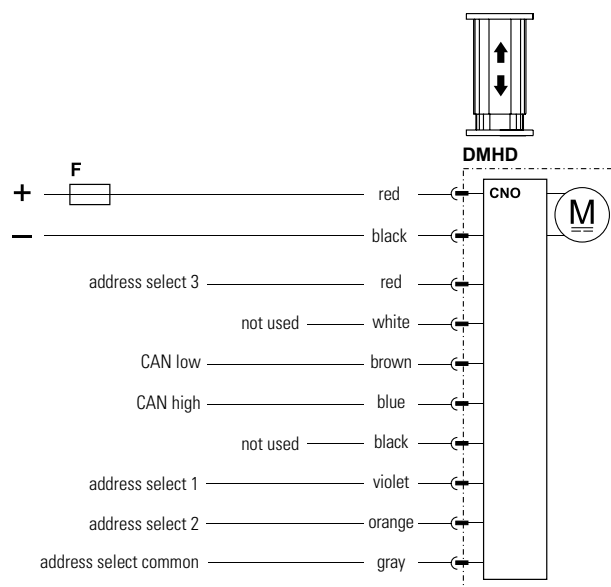

F Fuse

Control option CNO has an SAE J1939 CAN bus control interface/COO has a CANopen control interface that controls and monitors the actuator. Extend and retract commands are sent via CAN messages on the CAN low and CAN high pins. Address select 1, 2 and 3 pins can be used as a BCD encoded adder to the default address. This can be used when multiple actuators are located on a single bus.

DMHD – Electrical Connections

Option Type SYN

Actuator supply voltage	[Vdc]	9 - 16 DMHD12 DMHD24
Extend / retract input voltage	[Vdc]	9 - 32
Extend / retract input current	[mA]	6 - 22
Number of synchronized actuators		2 +
Max. actuator speed difference	[%]	25

Control option SYN works as option LXX but also has a synchronization feature, allowing two or more actuators having the SYN option to run in integrated motion.

When using the low-level extend and retract inputs on the master actuator, the slave(s) will follow. If there is a need to run an actuator individually, it is possible to put it into an override state by closing a switch (S3) connected to the red lead as shown in the wiring diagram.

Important design notes:

- Ensure that supply voltage to each actuator is within ± 1.0 V.
- Uneven loading between the actuators is not recommended, but the synchronization option can withstand its effects up to a 25% speed loss.
- For units with the synchronization option, the speed at a given load is 25% lower than for those without. This is true irrespective of the unit being in synchronization or override mode, or simply run individually.
- If one actuator encounters an overload condition, it will trip the overload protection and send a signal to each actuator on the network to stop. The units can be immediately reversed (unless they bind up the system), or they can continue in the same direction after a power reset.
- If power is lost at any time to any actuator, the actuators still powered will continue their last commanded move until told to stop, either by an individual current overload trip, or a stop signal sent from the master actuator.
- If communication is lost (i.e. brown/blue wires cut), the slaves will continue their last commanded move until they reach end of stroke or trip current overload. The master will continue its last commanded move unless commanded to stop with the switching leads, reaching end of stroke, or tripping current overload.
- After a large number of mid-stroke movements, the time difference between each unit receiving a signal to move (master vs. slave) will add to small variances in when the units start and stop. Since they are designed to run at the same speed, these small differences amount to a variance of position over time – even when load is applied. To address this concern, Thomson suggests running the units either to a fully extended or fully retracted position each cycle to re-align the units with each other to take out these added variances.
- In order to give the master and slave(s) enough time to communicate there must be at least 250 ms between each start and stop command.

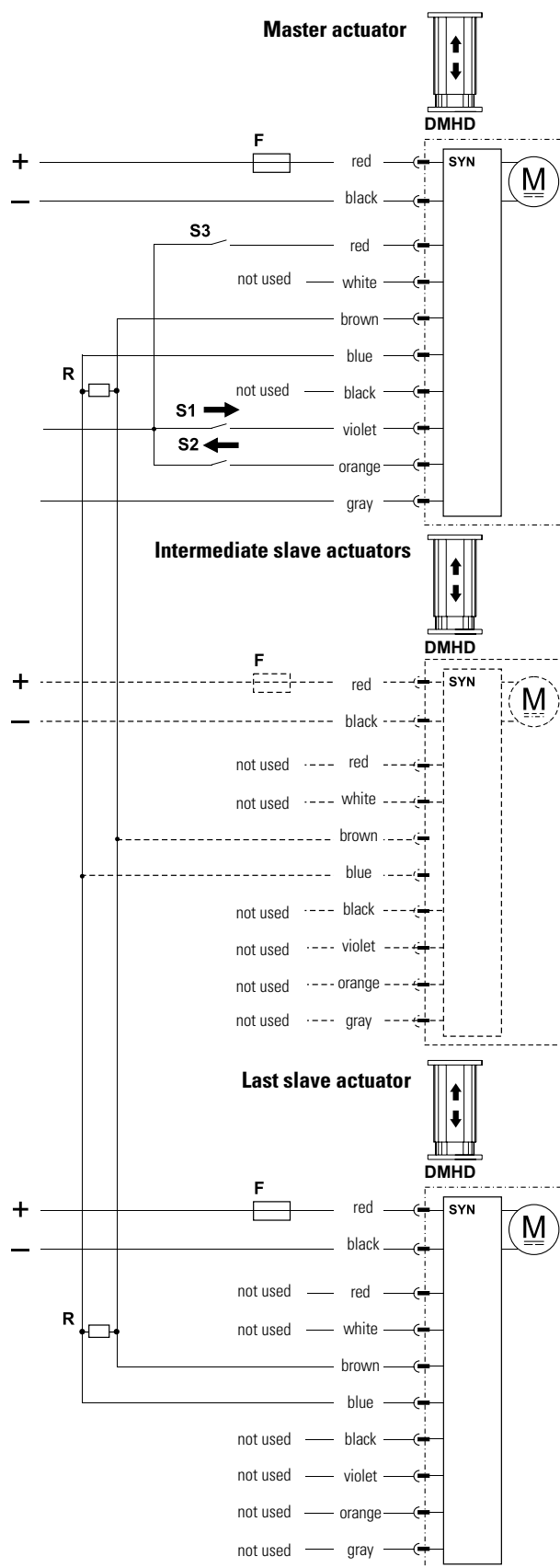

DMHD – Accessories

T-slot Bolt	
Designation	Part Number
M10 T-slot bolt	D800041

The T-slot bolt fits in to the T-slot running along the outer profile of the lifting column. The T-slot bolts can be used to mount the unit instead of using the upper mounting plate, or/and for attaching other components to the profile.

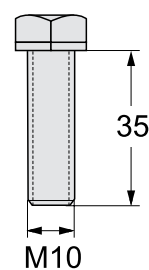

Dimensions

mm



DMD – Technical Features



Standard Features

- Self supporting column in extruded anodized aluminum with high load torque capability
- Onboard electronics with many optional functions
- 12 or 24 Vdc as standard input voltages
- Static load up to 18 kN (4000 lbf)
- Dynamic load up to 6.8 kN (1500 lbf)
- Stroke up to 24 inch
- Speed up to 71 mm/s (2.8 in/s)
- Protection class static IP65
- Rugged, robust and strong
- T-slot grooves along the entire profile
- Maintenance free

General Specifications

Screw type	acme or ball
Nut type DMDxxxxA (acme screw) DMDxxxxB (ball screw)	self locking lead nut load lock ball nut
Manual override	no
Anti-rotation	yes
Static load holding brake acme screw ball screw	no (self-locking) yes
Safety features	overload clutch auto reset thermal switch
Electrical connections	cable with flying leads
Compliances	CE

Optional Electrical Features

Potentiometer feedback

Compatible Controls

Contact customer support at www.thomsonlinear.com/cs

DMD – Technical Specifications

Mechanical Specifications		
Max. static load ⁽¹⁾	[N (lbf)]	
DMDxxxA (acme screw)		11350 (2500)
DMDxxxB (ball screw)		18000 (4000)
Max. dynamic load (Fx)	[N (lbf)]	
DMDxx05A5		1100 (250)
DMDxx10A5		2250 (500)
DMDxx20A5		2250 (500)
DMDxx05B5		2250 (500)
DMDxx10B5		4500 (1000)
DMDxx20B5		4500 (1000)
DMDxx21B5		6800 (1500)
Max. load torque, dyn. and static	[Nm (lbf-in)]	
DMDxx-xxA (acme screw)		565 (5000)
DMDxx-xxB (ball screw)		710 (6284)
Speed @ no load/max. load	[mm/s (in/s)]	
DMDxx05A5		54/32 (2.10/1.20)
DMDxx10A5		30/18 (1.20/0.70)
DMDxx20A5		15/12 (0.67/0.45)
DMDxx05B5		61/37 (2.40/1.40)
DMDxx10B5		30/19 (1.30/0.80)
DMDxx20B5		15/12 (0.60/0.45)
DMDxx21B5		15/11 (0.60/0.43)
Min. ordering stroke (S) length	[in]	4
Max. ordering stroke (S) length ⁽²⁾	[in]	24
Ordering stroke length increments	[in]	2
Operating temperature limits	[°C (F)]	-25 – 65 (-15 – 150)
Full load duty cycle @ 25 °C (77 °F)	[%]	25
End play, maximum	[mm (in)]	1.0 (0.04)
Protection class - static		IP65

(1) Max. static load at fully retracted stroke

Electrical Specifications		
Available input voltages ⁽¹⁾	[Vdc]	12, 24
Input voltage tolerance	[%]	± 10
Current draw @ no load/max. load ⁽²⁾	[A]	
DMD1205A5		12.0/34.0
DMD1210A5		7.0/27.0
DMD1220A5		5.0/15.0
DMD1205B5		7.0/27.0
DMD1210B5		5.0/25.0
DMD1220B5		4.0/13.0
DMD1221B5		4.0/20.0
DMD2405A5		6.0/17.0
DMD2410A5		4.0/13.0
DMD2420A5		2.0/7.5
DMD2405B5		4.0/14.0
DMD2410B5		2.0/12.5
DMD2420B5		2.0/7.5
DMD2421B5		2.0/10.0
Cable length	[mm (in)]	2000 (79)
Cable diameter	[mm (in)]	9 (0.35)
Cable leads cross section	[mm ² (AWG)]	
motor leads		2.5 (10)
potentiometer leads		1 (17)

(1) For other input voltages - contact customer support.

(2) For current draw for 36 Vdc input voltage models - contact customer support.



DMD – Dimensions

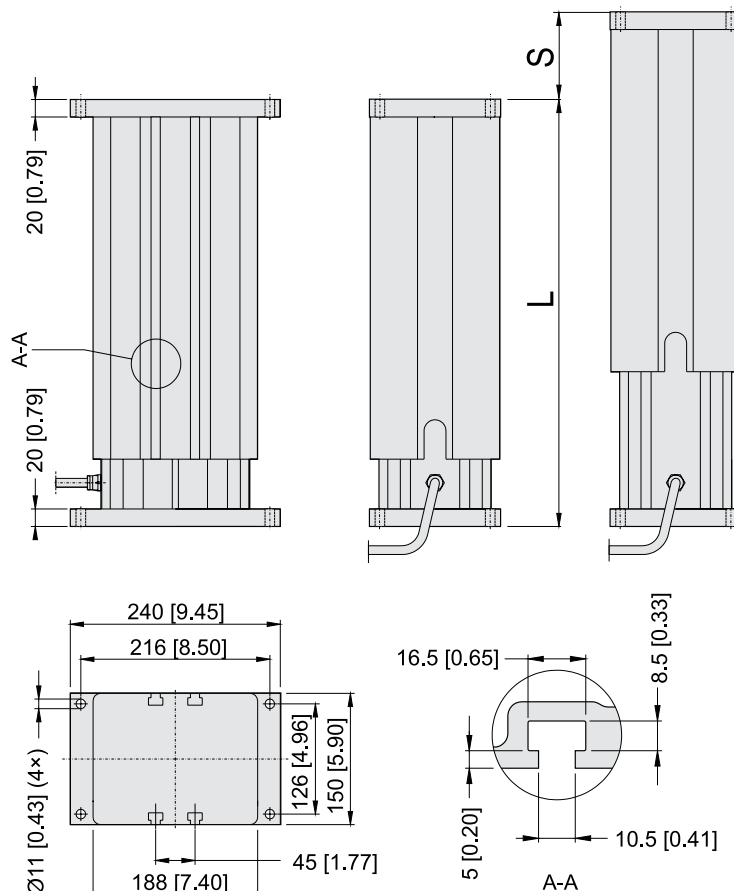

Dimensions	Projection
mm [inch]	

Stroke, Retracted Length and Weight Relationships											
Ordering stroke (S)	[in]	4	6	8	10	12	14	16	18	20	24
Retracted length, acme screw models (A)	[mm]	329.6	380.4	431.2	482.0	532.8	633.6	684.4	735.2	786.0	887.6
	[in]	13.0	15.0	17.0	19.0	21.0	24.9	26.9	28.9	30.9	34.9
Retracted length, ball screw models (A)	[mm]	369.6	420.4	471.2	522.0	572.8	673.6	724.4	775.2	826.2	927.6
	[in]	14.6	16.6	18.6	20.6	22.6	26.5	28.5	30.5	32.5	36.5
Add on length for option potentiometer	[mm]	55.0									
	[in]	2.17									
Weight, acme screw models	[kg]	18.7	20.2	21.6	23.1	24.6	27.3	28.7	30.2	31.7	34.6
	[lbf]	41.2	44.5	47.6	50.9	54.2	60.2	63.3	66.6	69.9	76.3
Weight, ball screw models	[kg]	20.4	21.9	23.4	24.8	26.3	29.0	30.4	31.9	33.4	36.3
	[lbf]	45.0	48.3	51.6	54.7	58.0	63.9	67.0	70.3	73.6	80.0
Add on weight for option potentiometer	[kg]	1.3									
	[lbf]	2.9									

DMD – Performance Diagrams

Speed and Current vs. Load - Diagram 1

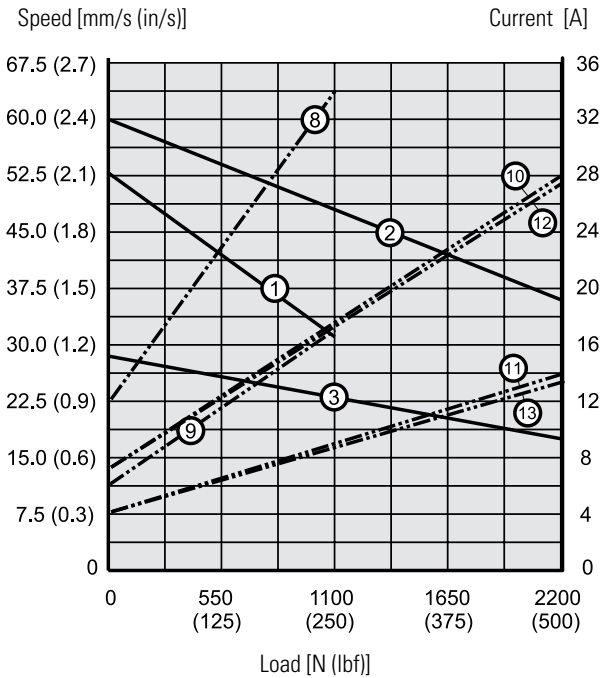

- | | |
|-------------------------------|---------------------------------|
| <u>Speed Curves Diagram 1</u> | <u>Current Curves Diagram 1</u> |
| 1: DMDxx05A5 | 8: DMD1205A5 |
| 2: DMDxx05B5 | 9: DMD2405A5 |
| 3: DMDxx10A5 | 10: DMD1205B5 |
| | 11: DMD2405B5 |
| | 12: DMD1210A5 |
| | 13: DMD2410A5 |

Speed and Current vs. Load - Diagram 2

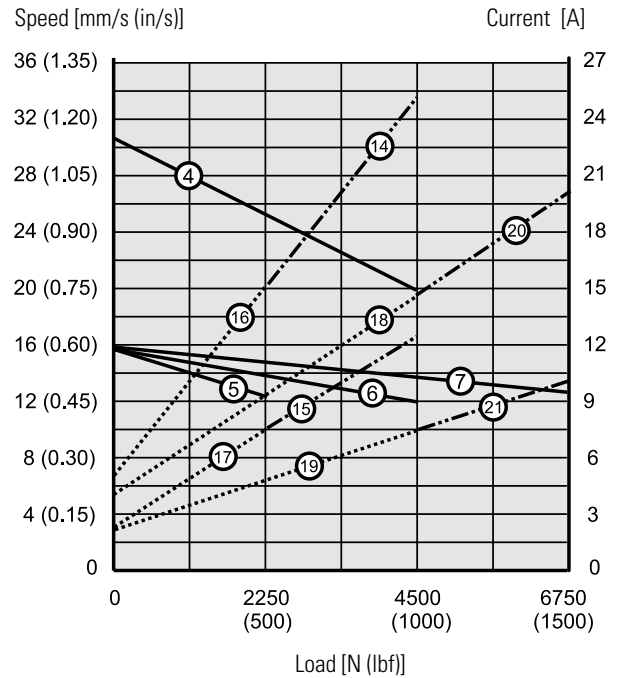

- | | |
|-------------------------------|---------------------------------|
| <u>Speed Curves Diagram 2</u> | <u>Current Curves Diagram 2</u> |
| 4: DMDxx10B5 | 14: DMD1210B5 |
| 5: DMDxx20A5 | 15: DMD2410B5 |
| 6: DMDxx20B5 | 16: DMD1220A5 |
| 7: DMDxx21B5 | 17: DMD2420A5 |
| | 18: DMD1220B5 |
| | 19: DMD2420B5 |
| | 20: DMD1221B5 |
| | 21: DMD2421B5 |

Contact customer service for data on 36 Vdc models.

Off Center Load Capacity

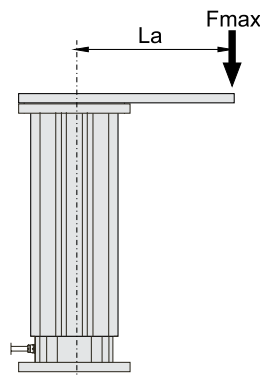
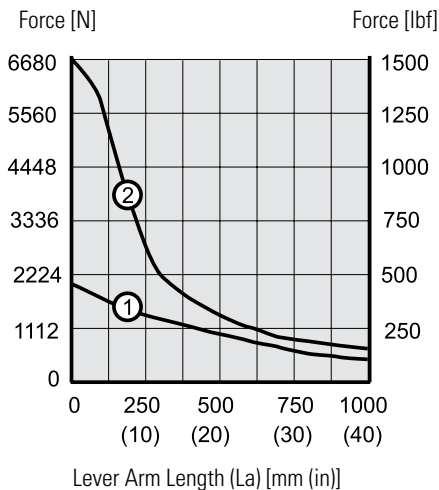

- 1: Acme screw models
2: Ball screw models

DMD – Ordering Key

Ordering Key			
1	2	3	4
DMD12-	05A5-	10	P0
1. Model and input voltage DMD12- = lifting column type DMD, 12 Vdc DMD24- = lifting column type DMD, 24 Vdc 2. Screw type, dynamic load capacity 05A5 - = 1100 N, acme, 54 mm/s 10A5 - = 2250 N, acme, 30 mm/s 20A5 - = 2250 N, acme, 15 mm/s 05B5 - = 2250 N, ball, 61 mm/s 10B5 - = 4500 N, ball, 30 mm/s 20B5 - = 4500 N, ball, 15 mm/s 21B5 - = 6800 N, ball, 15 mm/s		3. Ordering stroke length ⁽¹⁾ 04 = 4 inch (101.6 mm) 06 = 6 inch (152.4 mm) 08 = 8 inch (203.2 mm) 10 = 10 inch (254.0 mm) 12 = 12 inch (304.8 mm) 14 = 14 inch (355.6 mm) 16 = 16 inch (406.4 mm) 18 = 18 inch (457.2 mm) 20 = 20 inch (508.0 mm) 24 = 24 inch (609.6 mm) 4. Options ⁽²⁾ P0 = potentiometer <small>(1) Other stroke lengths available upon request. Contact customer support. (2) Leave position blank for no option.</small>	

DMD – Accessories

T-slot Bolt	
Designation	Part Number
M10 T-slot bolt	D800041

The T-slot bolt fits in to the T-slot running along the outer profile of the lifting column. The T-slot bolts can be used to mount the unit instead of using the upper mounting plate, or/and for attaching other components to the profile.

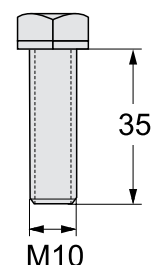

Dimensions

mm

DMD – Electrical Connections

Without Option		
Actuator supply voltage	[Vdc]	
DMD12		12
DMD24		24

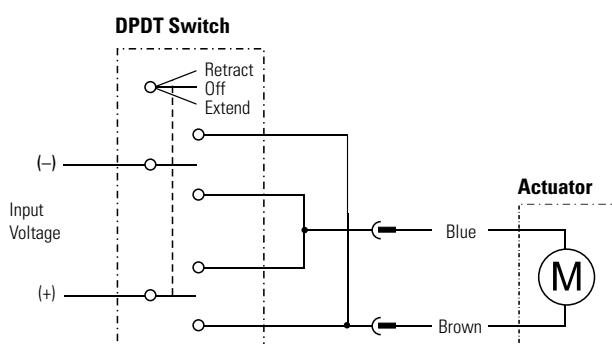

Connect the brown lead to positive and blue to negative to extend the actuator. Change polarity to retract the actuator.

Option Potentiometer		
Actuator supply voltage	[Vdc]	
DMD12		12
DMD24		24
Potentiometer type		wire-wound
Potentiometer max. input voltage	[Vdc]	32
Potentiometer max. power	[W]	2
Potentiometer linearity	[%]	± 0.25
Potentiometer output resolution	[ohm/mm]	
2 - 10 inch stroke		39
11 - 20 inch stroke		20
21 - 24 inch stroke		10

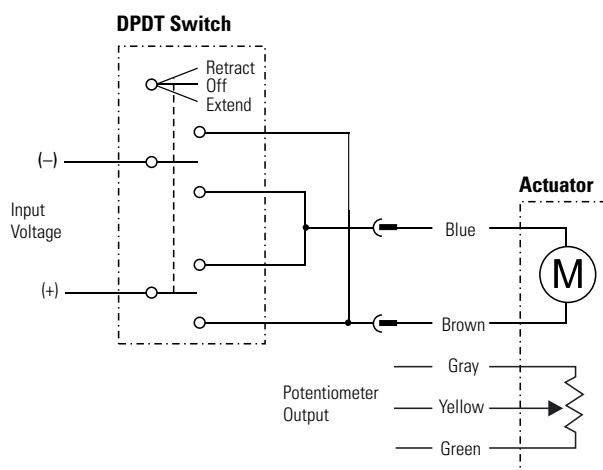

Connect the brown lead to positive and blue to negative to extend the actuator. Change polarity to retract the actuator. The potentiometer output has 0 ohm between gray and yellow when the actuator is fully extended.



DMA – Technical Features



Standard Features

- Self-supporting column in extruded anodized aluminium with high load torque capability
- Onboard electronics with many optional functions
- 1 × 230 standard input voltage
- Static load up to 18 kN (4000 lbf)
- Dynamic load up to 9 kN (2000 lbf)
- Stroke up to 24 inch
- Speed up to 71 mm/s (2.8 in/s)
- Protection class static IP45
- Rugged, robust and strong
- T-slot grooves along the entire profile
- Maintenance free

General Specifications

Screw type	acme or ball
Nut type DMDxx-xxA (acme screw) DMDxx-xxB (ball screw)	self-locking lead nut load lock ball nut
Manual override	no
Anti-rotation	yes
Static load holding brake acme screw ball screw	no (self-locking) yes
Safety features	overload clutch auto reset thermal switch
Electrical connections	cable with flying leads
Compliances	CE

Accessories

T-slot bolts

Compatible Controls

Contact customer support at www.thomsonlinear.com/cs

DMA – Technical Specifications

Mechanical Specifications		
Max. static load ⁽¹⁾ DMA22xxA (acme screw) DMA22xxB (ball screw)	[N (lbf)]	11350 (2500) 18000 (4000)
Max. dynamic load (Fx) DMA2205A5 DMA2210A5 DMA2220A5 DMA2205B5 DMA2210B5 DMA2220B5 DMA2221B5	[N (lbf)]	1100 (250) 2250 (500) 2250 (500) 2250 (500) 4500 (1000) 4500 (1000) 6800 (1500)
Max. load torque, dyn. and static DMAxxxxA (acme screw) DMAxxxxB (ball screw)	[Nm (lbf-in)]	565 (5000) 710 (6284)
Speed @ no load/max. load DMA2205A5 DMA2210A5 DMA2220A5 DMA2205B5 DMA2210B5 DMA2220B5 DMA2221B5	[mm/s (in/s)]	54/32 (2.10/1.20) 30/18 (1.20/0.70) 15/12 (0.67/0.45) 61/37 (2.40/1.40) 30/19 (1.30/0.80) 15/12 (0.60/0.45) 15/11 (0.60/0.43)
Min. ordering stroke (S) length	[in]	4
Max. ordering stroke (S) length	[in]	24
Ordering stroke length increments	[in]	2
Operating temperature limits	[°C (F)]	-25 – 65 (-15 – 150)
Max. on time	[s]	45
Full load duty cycle @ 25 °C (77 °F)	[%]	25
End play, maximum	[mm (in)]	1.0 (0.04)
Protection class - static, standard (optional)		IP45

(1) Max. static load at fully retracted stroke

Electrical Specifications		
Available input voltages	[Vac]	1 × 230 ⁽¹⁾
Input voltage tolerance	[%]	± 10
Current draw @ no load/max. load DMA2205A5 DMA2210A5 DMA2220A5 DMA2205B5 DMA2210B5 DMA2220B5 DMA2221B5	[A]	1.10/1.55 0.85/1.30 0.95/1.25 0.85/1.30 0.85/1.30 0.85/1.30 0.85/1.25
Cable length	[mm (in)]	0.6 (24)
Cable diameter	[mm (in)]	9 (0.35)
Cable leads cross section	[mm ² (AWG)]	2.5 (14)

(1) Capacitor 10 µF (p/n 9200-448-003) required to run the actuator.



DMA – Dimensions

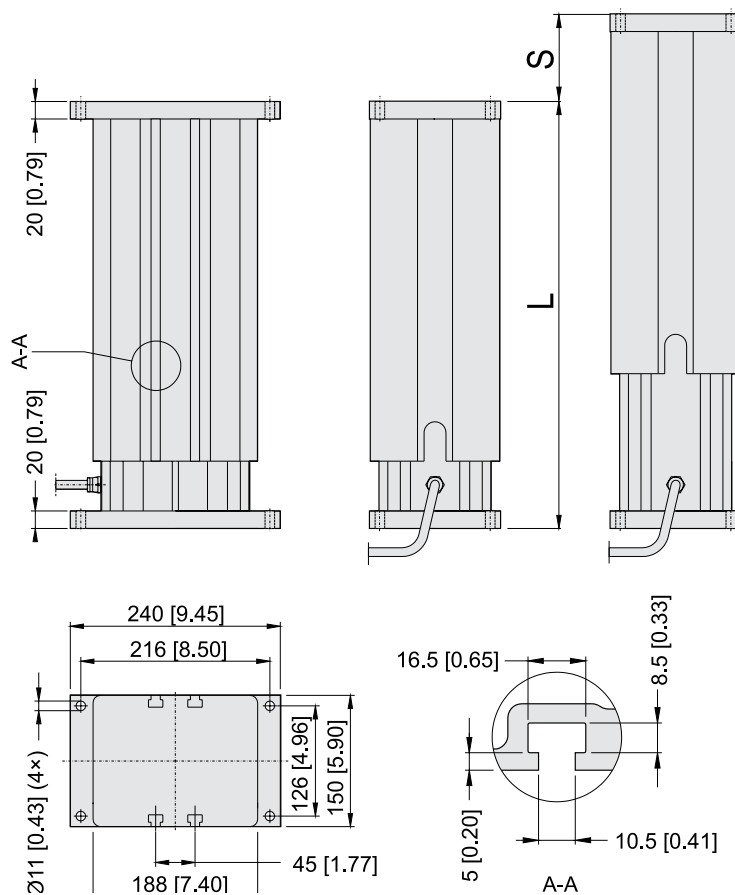

Dimensions	Projection
mm [inch]	

Stroke, Retracted Length and Weight Relationships											
Ordering stroke (S)	[in]	4	6	8	10	12	14	16	18	20	24
Retracted length, acme screw models (A)	[mm]	329.6	380.4	431.2	482.0	532.8	633.6	684.4	735.2	786.0	887.6
	[in]	13.0	15.0	17.0	19.0	21.0	24.9	26.9	28.9	30.9	34.9
Retracted length, ball screw models (A)	[mm]	369.6	420.4	471.2	522.0	572.8	673.6	724.4	775.2	826.2	927.6
	[in]	14.6	16.6	18.6	20.6	22.6	26.5	28.5	30.5	32.5	36.5
Weight, acme screw models	[kg]	20.9	22.4	23.8	25.3	26.8	29.5	30.9	32.4	33.9	36.8
	[lbf]	46.1	49.4	52.5	55.8	59.1	65.0	68.1	71.4	74.7	81.1
Weight, ball screw models	[kg]	22.6	24.1	25.6	27.0	28.5	31.2	32.6	34.1	35.6	38.6
	[lbf]	49.8	53.1	56.4	59.5	62.8	68.8	71.9	75.2	78.5	85.1

DMA – Performance Diagrams

Speed and Current vs. Load - Diagram 1

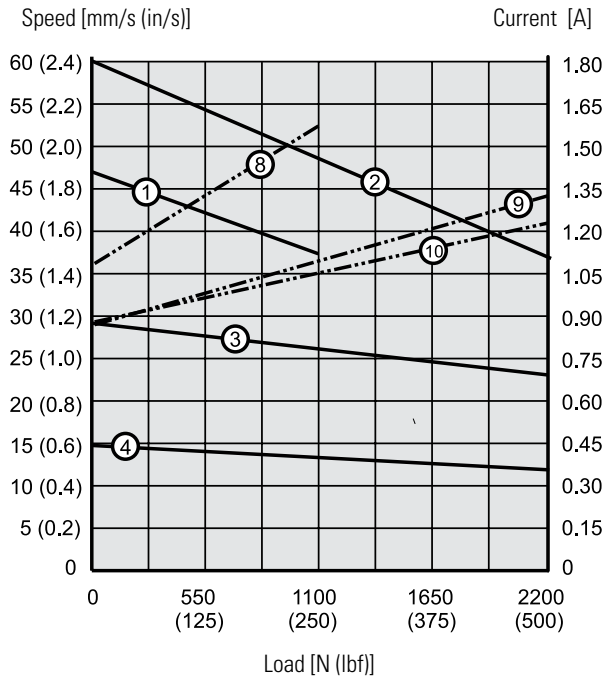

Speed Curves Diagram 1

- 1: DMA2205A5
- 2: DMA2205B5
- 3: DMA2210A5
- 4: DMA2220A5

Current Curves Diagram 1

- 8: DMA2205A5
- 9: DMA2205B5(10A5)
- 10: DMA2220A5

Speed and Current vs. Load - Diagram 2

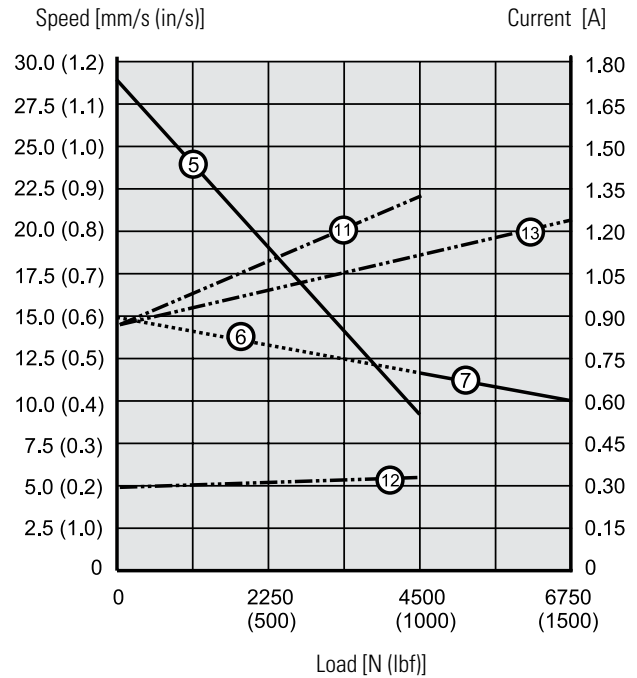

Speed Curves Diagram 2

- 5: DMA2210B5
- 6: DMA2220B5
- 7: DMA2221B5

Current Curves Diagram 2

- 11: DMA2210B5(20B5)
- 12: DMA2220B5
- 13: DMA2221B5

Off Center Load Capacity

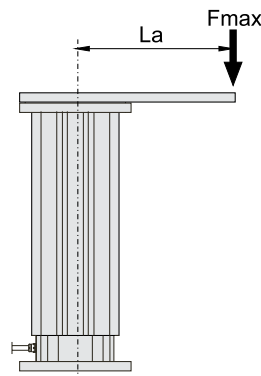
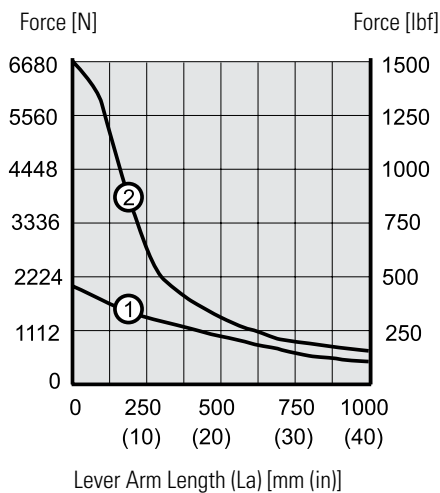

- 1: Acme screw models
- 2: Ball screw models



DMA – Ordering Key

Ordering Key		
1	2	3
DMA22	05A5-	10
1. Model and input voltage DMA22 = lifting column type DMA, 1 × 230 Vac 2. Screw type, dynamic load capacity 05A5 - = 1100 N, acme, 54 mm/s 10A5 - = 2250 N, acme, 30 mm/s 20A5 - = 2250 N, acme, 15 mm/s 05B5 - = 2250 N, ball, 61 mm/s 10B5 - = 4500 N, ball, 30 mm/s 20B5 - = 4500 N, ball, 15 mm/s 21B5 - = 6800 N, ball, 15 mm/s		3. Ordering stroke length ⁽¹⁾ 04 = 4 inch (101.6 mm) 06 = 6 inch (152.4 mm) 08 = 8 inch (203.2 mm) 10 = 10 inch (254.0 mm) 12 = 12 inch (304.8 mm) 14 = 14 inch (355.6 mm) 16 = 16 inch (406.4 mm) 18 = 18 inch (457.2 mm) 20 = 20 inch (508.0 mm) 24 = 24 inch (609.6 mm) (1) Other stroke lengths available upon request. Please contact customer support. (2) Leave position blank for no option.

DMA – Accessories

T-slot Bolt	
Designation	Part Number
M10 T-slot bolt	D800041

The T-slot bolt fits in to the T-slot running along the outer profile of the lifting column. The T-slot bolts can be used to mount the unit instead of using the upper mounting plate, or/and for attaching other components to the profile.

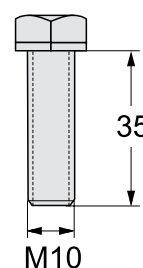

Dimensions
mm

DMA – Electrical Connections

Input Voltage 230 Vac

Actuator supply voltage DMA22	[Vac]	1 × 230
----------------------------------	-------	---------

Acme screw models (no anti-coast brake)

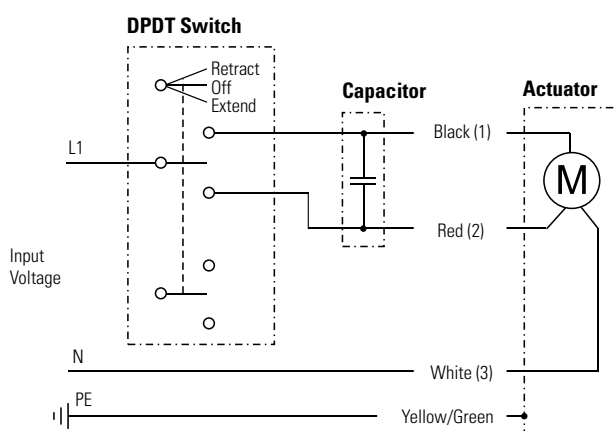

Ball screw models (with anti-coast brake)

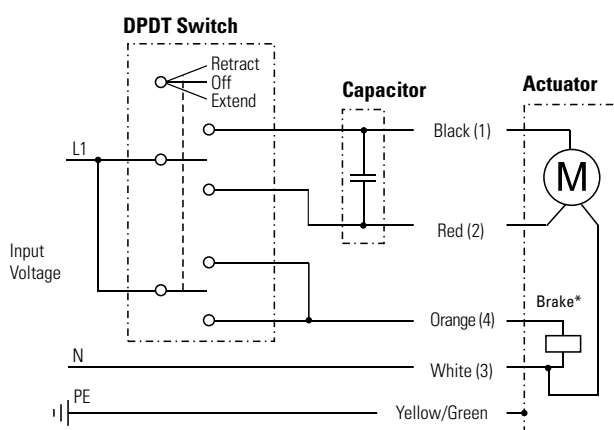

Leads can be either color or number marked. To be able to run the actuator, a 10 μF capacitor must be connected between black (1) and red (2) leads. See page 54 for ordering of capacitors. Connect black (1) lead to L1 and white (3) lead to N (neutral) to retract the actuator. Change L1 from lead black (1) to lead red (2) to extend the actuator. Ball screw models have an anti-coast brake*, that must be released during motion, which is done by connecting orange (4) lead to L1. Acme models do not have any anti-coast brake.